



DATASHEET
Movexx P300 600 x 1000



Technische Daten P300 600 x

Rahmen	Stahl, pulverbeschichtet
Abtrieb	24V DC, 300W, 100 rpm
Gewicht	85 kg
Ladefähigkeit	300 kg
Zugkraft (N)	800N
Batterie	Eingebaut
Geschwindigkeit	Max. 5 km/h
Antriebsrädern	Vollgummi ø250x80 mm
Breite	600mm
Länge	1323mm
Deichsel Höhe	750-1360mm (variabel)
Zusammengeklappt	750mm
Schalldruckpegel	63,8 dB
Zu verwenden vom	-40 °C / 70 °C
Schutzart	Machine IP44

Abmessungen P300 600 x 1000

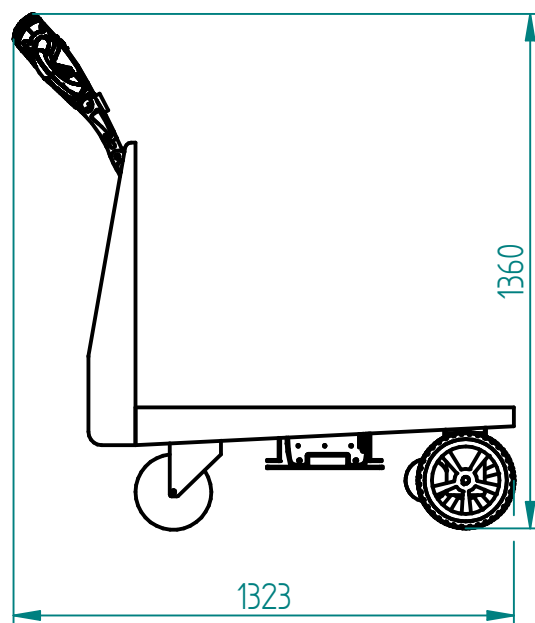
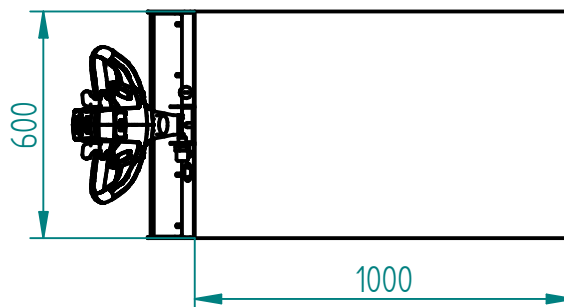

Zugkraft P300 600 x 1000 (in KG)

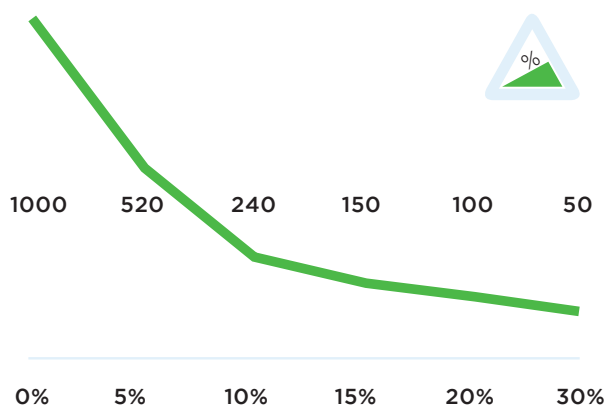

Standard P300 600 x 1000



Standard parts P300 600 x 1000

Batterieanzeige
LBF318 LED



Artikelnummer:
M0123

Eingebautes La-
degerät 24V4Ah +
Indikator



Artikelnummer:
M0246

Vollgummi An-
triebsrad, Schwarz



*Vollgummi Antriebsrad,
schwarz*

Artikelnummer:
M0248

Einstellbare Deichsel-
kopf



Standard parts P300 600 x 1000

Antrieb T1000, ohne
Bremse



Artikelnummer:
M1032

Akku 12 volt 20 Ah



Artikelnummer:
M0076

Sicherheitsschalte



2 programmierbare
Geschwindigkeiten



Optionen P300 600 x 1000



**ZUSCHL Antriebsrad
Luftreifen non-m
GRAU**

*ZUSCHLAG Antriebsrad
Luftreifen non-marking
GRAU*

Bestellnummer
OPT0156



**ZUSCHL Antrieb
Luftreifen Schaum 2b
SCH**

*ZUSCHLAG Antriebsrad
Luftreifen Schaumkern
2.0b SCHWARZ*

Bestellnummer
OPT0158



**ZUSCHL Antriebsrad
Vollgummi nonm.
GRAU**

Bestellnummer
OPT0161



**ZUSCHLAG An-
triebsrad non-mar-
king GELB**

Bestellnummer
OPT0163



**Elektromagnetische
Bremse T1000**

Bestellnummer
OPT0004



Hupe 90dB

Bestellnummer
OPT0045



Hupe 103 dB

Bestellnummer
OPT0059



Not-Aus Komplet

Bestellnummer
OPT0063



**Blitzlicht gusseisen
Deichselkopf**

Bestellnummer
OPT0076



**Bellybutton 2-Schritt
Reset**

*Nach Bellybutton ge-
brauch aus/ein schal-
tung erforderlich*

Bestellnummer
OPT0168



**Ein- / Ausschalter
Maschine**

Bestellnummer
OPT0016



**Stundenzähler kom-
plette**

Bestellnummer
OPT0056

Optionen P300 600 x 1000

Antistatik-Streifen



Bestellnummer
OPT0058

Kodeschloss



Bestellnummer
OPT0068

Schrank mit 2 Rolladen P300-600x1000



Bestellnummer
OPT0126

Dokument halter



Bestellnummer
OPT0127

Zündschloss Verschiedenschliessend



Bestellnummer
OPT0145

Zündschloss gleichschliessend



Bestellnummer
OPT0146

Zündschloss unter grosser Deichselkopf



*Verschiedenschliessend
nur mit OPT0171*

Bestellnummer
OPT0147

Zündschloss unter grosser Deichselkopf



*Gleichschliessend. Nur
mit OPT0171*

Bestellnummer
OPT0148

Deichselkopf Aus-schlag Begrenzung



Bestellnummer
OPT0169

Kundenspezifische Programmierung



Bestellnummer
OPT0170

Großere Deichsel



Mit 6 Schalterpositionen

Bestellnummer
OPT0171

Einsteller Italsea



Bestellnummer
D0003

Optionen P300 600 x 1000



U-Rahmen für Abfall-
behälter 1000/1100L

Bestellnummer
OPT0088



Willecke
Hebe- und Fördergeräte GmbH
 An der Becke 7 (Gewerbegebiet Ludwigstal)
 D-45527 Hattingen
 Tel./Fax.: +49 (0) 2324 / 39112 - 0 / -22
 info@willecke.de; www.willecke.de

